

Temperature Dry Well Calibrator Model CTD9100-1100

WIKA Data Sheet CT 41.29

Applications

- Testing and calibration of temperature measuring instruments
- Reference instrument for works laboratories for the calibration of thermometers
- On-site calibration

Special Features

- High accuracy and stability at high temperatures
- Temperature range 200 ... 1100 °C
- Possibility to check temperature switches
- Low weight and compact design
- Simple operation



Temperature Dry Well Calibrator Model CTD9100-1100

Description

Versatile in application

Nowadays, fast and simple testing of thermometers is a "must", especially if it concerns the reliability of operation of plant and machinery.

The portable calibrators of the CTD9100 family are particularly suited to local calibration tasks. They are extremely user-friendly. Due to their compact design and their low weight, the devices can be taken and used almost anywhere.

The new equipment concept connects a stable heat source with a counter-current forced-cooling system, which keeps the temperature low in the upper part of the calibrator. Thus, industrial temperature sensors can be calibrated even more efficiently, without heating the connecting head or the handgrip.

Regular monitoring of temperature sensors helps to recognise failures promptly and shorten downtimes.

Easy to use

The temperature dry well calibrators of the CTD9100 series work with temperature-controlled metal blocks and interchangeable inserts.

The calibration temperature, adjusted simply using two buttons on the controller, can be controlled very quickly. The actual temperature of the heated block is displayed simultaneously on a large, 2-lines high-contrast LCD screen. Thus reading errors are virtually eliminated.

Thermometers with different diameters can be fitted into the calibrator using inserts, drilled to suit.

A new block design, with improved temperature homogeneity at the calibrator's lower range, leads to smaller measurement uncertainties.

Dimensions in mm

Front view

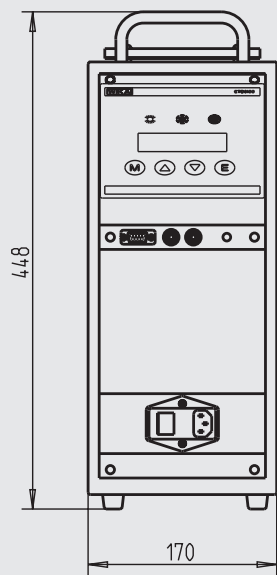

Side view

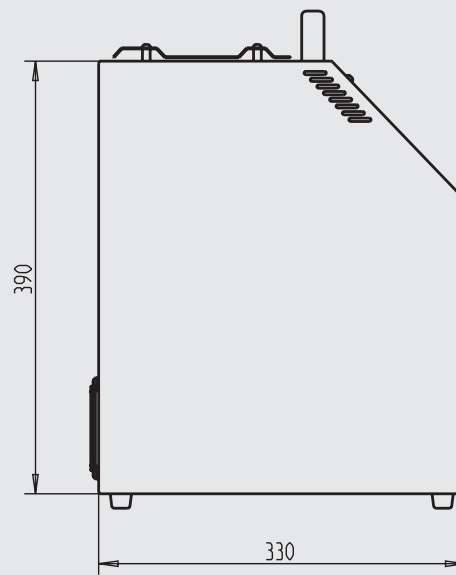

Rear view



Top view

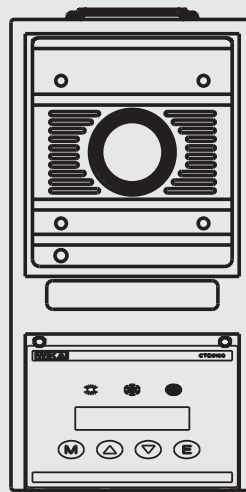

Specifications

Model CTD9100-1100

Temperature range	°C	200 ... 1100
Accuracy		± 3 K
Stability		± 0.4 K at 1000 °C
Display resolution	°C	0.1 / 0.01
Heating time	min	50
Cooling time ¹⁾	min	150
Immersion depth	mm	175
Insert dimensions	mm	Ø 44 x 300
Interface		RS-232
Power supply	AC	220 V 50/60 Hz or 110 V 50/60 Hz
Power consumption	VA	850
Dimensions (W x H x D)	mm	170 x 390 x 330
Weight	kg	12

1) from 1100°C to 200°C

Inserts

1. The insert has several bores into which the thermometer being calibrated and one of the additional customer reference thermometers, for comparative calibration, can be inserted. The block is either heated or cooled to the desired calibration temperature. Once a stable temperature has been reached, the temperature probes to be calibrated can be compared with the reference thermometer. The documentation of this comparison represents the calibration.
2. The ceramic insulator is fitted into the insert sheath and its bore aligned with respect to the insert. This prevents the hand-grip or process head of the transmitter from overheating.
3. The sleeve remover consists of a stainless steel rod with a threaded end, which can be screwed into the top of the insert sleeve. The insert sleeve must be aligned in such a way, so that the grooves sit directly over the controlled and monitored thermometers.

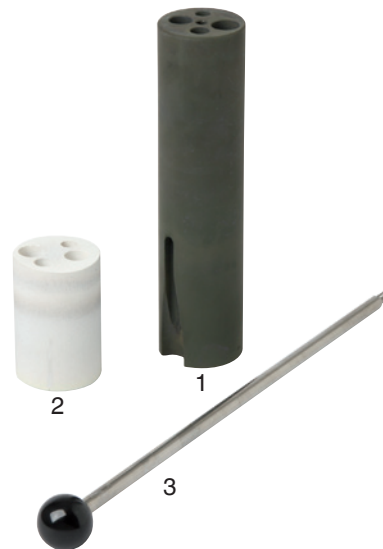

Scope of delivery

- Dry Well Temperature Calibrator
- Power lead, 1.5 m with safety plug
- Insert with four bores: 7 mm, 9 mm, 11 mm and 13.5 mm
- Ceramic top insulator
- Insert replacement tools
- Testing connection cables
- Operating Instructions
- 3.1 calibration report per DIN EN 10204

Options

- DKD calibration certificate

Accessories

- Inserts, undrilled and drilled to specification
- Carrying case
- Power lead for Switzerland
- Power lead for USA/Canada
- Power lead for UK

Products and Services within our Calibration Technology Program

- | | |
|--|--|
| <ul style="list-style-type: none">■ DKD calibration services for pressure■ Repair of calibration units of all makes■ Portable pressure measuring devices for test and calibration tasks■ Precision pressure measuring units and pressure controllers■ Primary standards for pressure■ Testing technology system solutions | <ul style="list-style-type: none">■ DKD calibration services for temperature■ Dry well temperature calibrators■ Calibration baths and furnaces■ Temperature measuring instruments for test and calibration tasks■ Precision thermometers■ Primary standards for temperature■ Consulting and seminars |
|--|--|

The specifications given in this document represent the state of engineering at the time of publishing. We reserve the right to make modifications to the specifications and materials.

